

We touch your **electricity** everyday!

**WiNtrip**

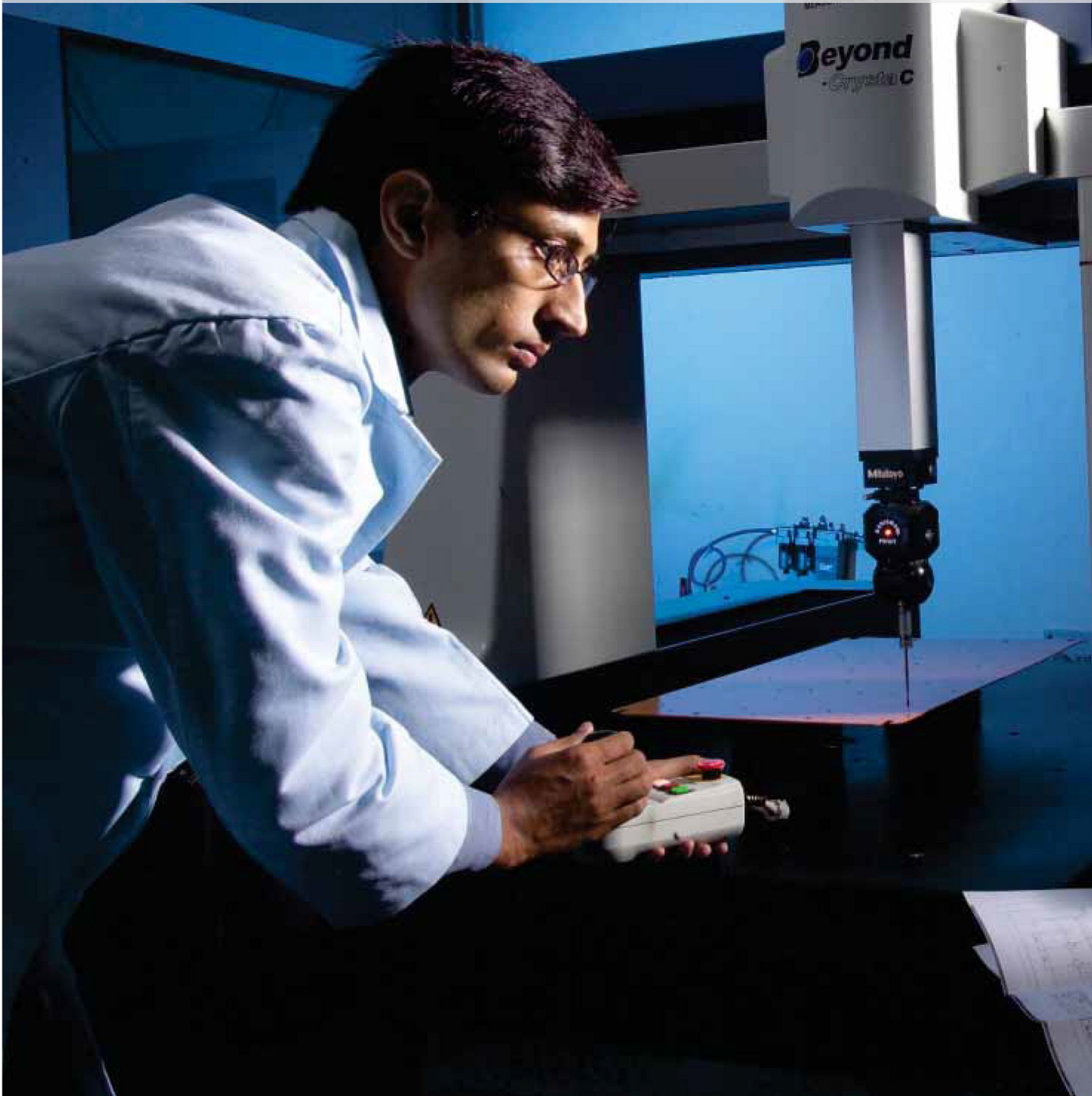

C&S Electric Ltd. is amongst the leading suppliers of electrical equipment in India and is India's largest exporter of industrial switchgear. It's wide range of electrical and electronic products find application in power generation, distribution, control, protection and final consumption.



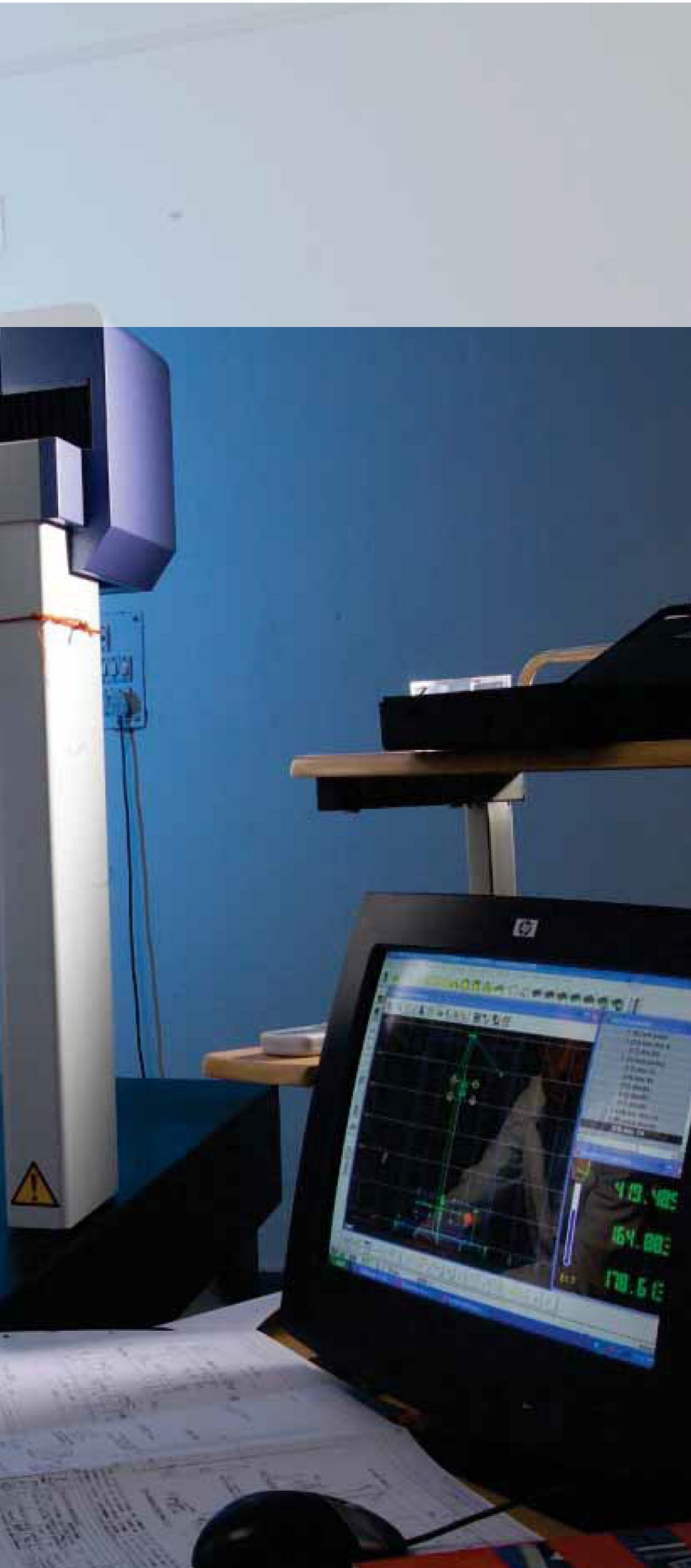

## CONTENTS

Introduction	5
Highlights	6
Technical Data	7
Features - Performance	8
Product Reference - RCCB	10
Dimensions	11



## WiNtrip

Residual Current Circuit Breaker



From Bungalows to High Risers, from Trade Centres to Hotels, from Clinics to Hospitals, from escalators to elevators electricity is the foremost requirement. Electricity has become an integral part of our life so common to our daily requirements that we forget its intricacies and hazardous behaviour.





Day after day we come across many un to do events hampering human lives due to negligent usage of electricity. Even large number of Industrial and Domestic fire are attributed to and caused by electricity.

Faulty insulated equipments or wrong usage of electrical devices cause current to flow through insulation to the earth. This is leakage current. This current poses two severe risk factors which are

- Fire Risk
- Electrocutation Risk

Residual Current Circuit Breaker provides the function of isolation switching and earth leakage protection of electrical circuits. It also provides the indirect protection of the human body against the dangerous effects of electric current. It is also a protective device against fire caused by the electrical circuit fault.

### Physiological Effect of Electric Current on Human Body

- |           |   |  |
|-----------|---|--|
| 500 mA    |  | Immediate cardiac arrest resulting in death  |
| 70-100 mA |  | Cardiac fibrillation; the heart begins to vibrate and and no longer beats at a steady rate. This situation is dangerous since it is irreversible |
| 20-30 mA  |  | Muscle contraction can cause respiratory paralysis   |
| 10 mA     |  | Muscle contraction: the person remains "stuck" to the conductor  |
| 1-10 mA   |  | Prickling sensations   |

As per Indian Electricity Rules 1956 at all installations with load above 5 KW use of RCCB is compulsory





A state-of-the-art product fit for Industrial, Residential and Commercial applications. It is one piece residual current circuit breaker which is used both for control and isolation of electrical circuits. It provides total protection to all living beings against direct and indirect contact as well as to installations, big or small, against insulation faults. **Human life is valueless and WiNtrip RCCB is the solution provider for safeguarding it.**

Majority of mishaps occur due to current leakage consequently leading to fire. WiNtrip RCCB of the required rating instantly detects this leakage and terminates the supply reducing the risk of any kind of fire. The range is available in AC Residual Tripping Characteristics in 2 & 4 Pole configurations in 10, 16, 20, 25, 32, 40, 63, 80 & 100Amps in 30, 100 & 300mA sensitivity.

- Provides protection against earth fault/leakage current and also fulfill the function of isolation.
- Automatically measures and disconnect the circuit when earth fault/leakage current occurs and exceeds the rated sensitivity.
- High short-circuit current withstand capacity - 6kA
- Dual termination possible for cable and comb type busbar connection
- Equipped with finger protected connection terminals (IP20)
- Fire resistant plastic parts to withstand abnormal heating and strong impact
- Independent of power supply and line voltage. Also free from external voltage fluctuation.
- Incorporates a filtering device for prevention of nuisance tripping due to transient voltage
- Easy padlocking facility.



# Technical Data - Characteristics

Standards			IS 12640-1:2008
Residual tripping characteristics			AC
Tripping time at $I_{\Delta n}$	Instantaneous	ms	<40
	Selective	ms	>150
Rated current		A	10, 16, 20, 25, 32, 40, 63, 80 & 100
Rated residual current $I_{\Delta n}$		mA	30, 100, 300
Calibration temperature		°C	30
Number of poles versus modules			1
Rated voltage $U_n$	2P AC	V	240
	4P AC	V	415
Frequency		Hz	50/60
Maximum service voltage $U_{bmax}$		V	2P=265 / 4P=455
Minimum service voltage $U_{bmin}$		V	2P=100 / 4P=190
Power supply			Top / Bottom
Rated making and breaking capacity ( $I_m$ )		A	500 (or 10x $I_n$ )
Residual making and breaking capacity ( $I_{\Delta m}$ )		A	500 (or 10x $I_n$ )
Conditional short-circuit capacity ( $I_{nc}$ )		A	6000 Fuse 100A gLgG
Conditional residual short-circuit capacity ( $I_{\Delta c}$ )		A	6000 Fuse 100A gLgG
Grid distance (safety distance between two devices)		mm	35
Isolator application			yes
Insulation degree	Insulation voltage	V (DC)	660
	Shock voltage (1.2/50 $\mu$ s)	kV	6
	Insulation resistance	m $\Omega$	1000
	Dielectric strength	V	2500
Shock resistance (in x, y, z direction) (EN / IEC 60077/16.3)		40g	18 shocks 5 ms
Vibration resistance (in x, y, z direction; EN / IEC 60068-2-6)		1.5g	30 min, 0~80Hz
Endurance	electrical at $U_n, I_n$		10000
	mechanical at $U_n, I_n$		20000
Protection degree (outside/inside electrical enclosure) with door			IP20 / IP40
Self extinguish degree (according to UI94)			V2
Tropicalisation (acc. to EN/IEC 60068-2, DIN 40046)		°C/RH	+55 / 95%
Pollution degree (acc. EN/IEC 60947-1)			3
Operating temperature			AC (-5 ~ +60)
Storage temperature		°C	-25~+70
Terminals capacity	Rigid cable min/max (top)	mm <sup>2</sup>	1.5/25
	Flexible cable min*/max (top)	mm <sup>2</sup>	1.5/25
	Rigid cable min/max (bottom)	mm <sup>2</sup>	1.5/25
	Flexible cable min*/max (bottom)	mm <sup>2</sup>	1.5/25
	(*Flexible cable 0.75/1/1.5 mm <sup>2</sup> with cable lug)		
Busbars systems	Pin		yes
	Fork		yes
CE marking			yes
Torque	Top / Bottom	Nm	5/5



Test Button



Rated current  $I_n$  /  $I_{\Delta n}$



DIN Rail Mounting

Type AC		
Rated Current setting $I_n$	A	10, 16, 20, 25, 32, 40, 63, 80, 100
Residual current $I_{\Delta n}$	mA	30, 100, 300
Rated voltage AC $U_n$	V	2P : 240; 4P : 415
Minimum operating voltage $U_{min}$	V	2P : 100; 4P : 190
Mechanical/electrical endurance		20000 / 10000
Tropicalisation acc.to EN/IEC 60068-2-28/2-30 and DIN 40046		95% RH at 55 °C
Terminal capacity exible/rigid cable	mm <sup>2</sup>	25/25
Poles		2, 4
Nuisance tripping resistance		250A 8/20us; 200A 0.5us - 100kHz
Ambient temperature	°C	-5 upto 40
Weight	g	2P- 224.5; 4P-409

Short-circuit Capacity	
Acc. to EN/IEC 61008-1	$I_m = 500A$
Making and breaking capacity	$I_{Dm} > 500A$ from 16 upto 40A $I_{Dm} = 10I_n$ from 63 upto 100A
Short-circuit capacity	$I_{nc} = 6000A$ at 240/415V Fuse 80A gG

### Normal operation and mounting requirement

1. Ambient temperature  $-5^{\circ}C \sim +40^{\circ}C$  •Altitude above sea level less than 2000 m.
2. Humidity not exceeding 50% at  $40^{\circ}C$  and not exceeding 90% at  $25^{\circ}C$ .
3. Installation class II or III.
4. Pollution degree 3.
5. All equipments used should be properly earthed.
6. For right operation should ensure that the neutral conductor on the load side of the RCCB must not be linked to earth. Otherwise tripping may be impaired or nuisance tripping may occur.
7. Installation method DIN Rail mounting type.
8. Product should be installed vertically at the place where there shall be no severe impact and vibration.
9. The product is switched on when the handle is at upper position.

### RCCB Tripping Cause Detection & Remedy

1. Switch OFF all the MCBs connected to the circuit downstream the RCCB.
2. Switch ON the RCCB and switch ON the MCBs one by one.
3. During switching ON of a particular circuit RCCB keeps tripping frequently.
4. In this circuit the fault persists.
5. Isolate the faulty circuit, correct the fault. Now the RCCB will not trip.

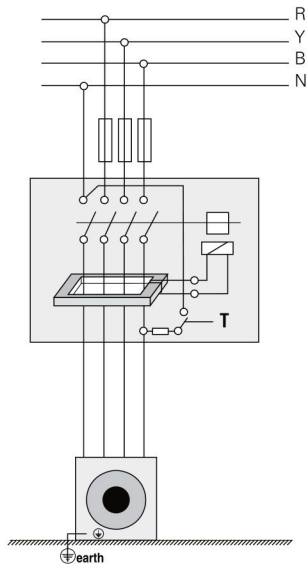

### Working Principle

The RCCB works on the current balance principle. The supply conductors are passed through a toroid and form the primary windings of a current transformer. Its secondary winding is connected to a highly sensitive electromagnetic trip relay, which operates the trip mechanism.



In a healthy circuit, sum of the current in phases, is equal to the current in the neutral and the vector sum of all current is equal to zero. If there is any insulation fault in the current and leakage current flows to earth, the current do not balance and their vector sum is not equal to zero. This imbalance is detected by the core balanced current transformer, the RCCB is tripped and supply to load is interrupted.

### Sensitivity Selection Criteria

Sensitivity	Application
30mA	Designed for additional protection against direct contact. The 30 mA RCCB protects against leakage currents and indirect contact with earth loop impedance up to 1667 Ohms.
100mA	Is suitable for protection against indirect contact and leakage current for larger installations. The 100 mA RCCB's operate within 30 ms, but do not provide the same level of personal protection as the 30 mA units. The 100 mA RCCB protects against leakage currents and indirect contact with earth loop impedance up to 500 ohms.
300mA	A less sensitive protection device suitable for large installations having high levels of leakage current. 300 mA RCCB's protect against leakage current and indirect contact up to 167 ohms earth loop impedance.

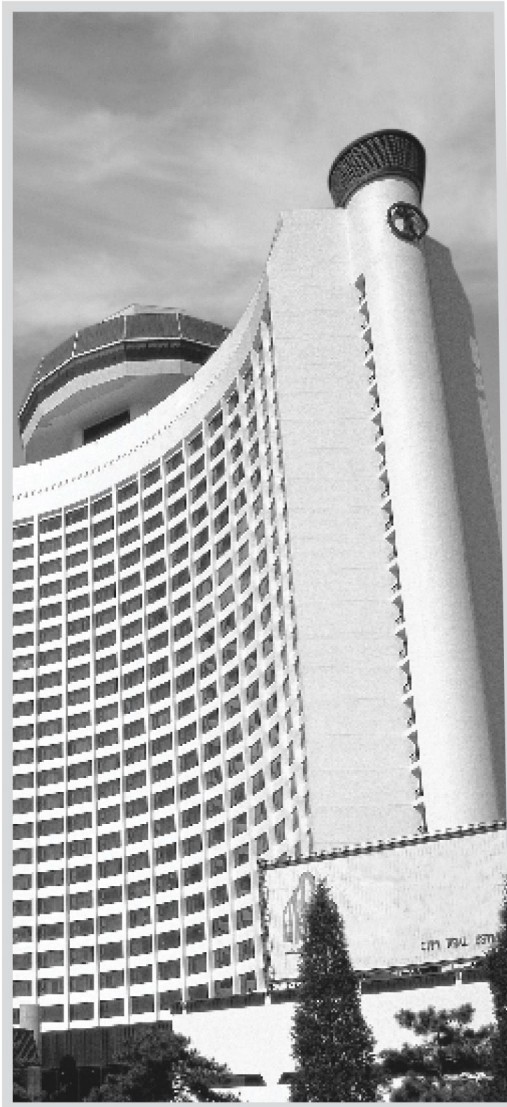
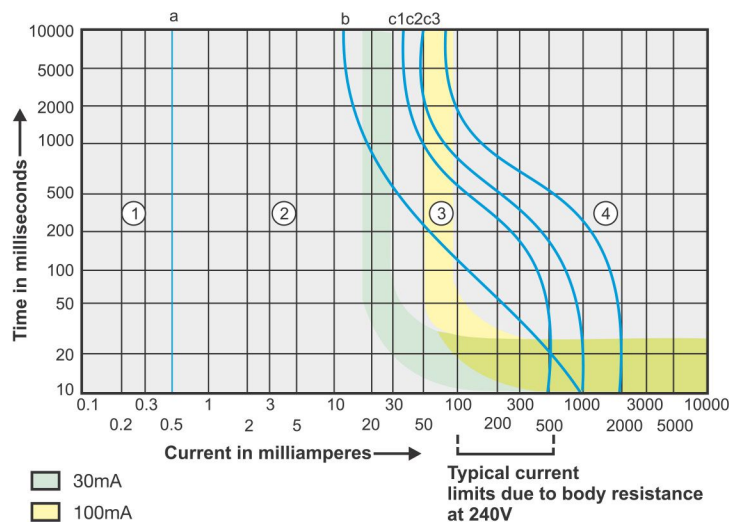
### Current Limiting Curve

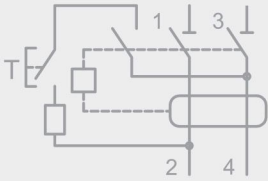

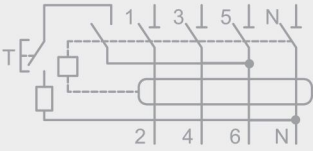
Wiring Diagram	Rated Current	Reference	Sensitivity
  Double Pole	10	CSRB2P10A30 CSRB2P10A100 CSRB2P10A300	30 100 300
	16	CSRB2P16A30 CSRB2P16A100 CSRB2P16A300	30 100 300
	20	CSRB2P20A30 CSRB2P20A100 CSRB2P20A300	30 100 300
	25	CSRB2P25A30 CSRB2P25A100 CSRB2P25A300	30 100 300
	32	CSRB2P32A30 CSRB2P32A100 CSRB2P32A300	30 100 300
	40	CSRB2P40A30 CSRB2P40A100 CSRB2P40A300	30 100 300
	63	CSRB2P63A30 CSRB2P63A100 CSRB2P63A300	30 100 300
	80	CSRB2P80A30 CSRB2P80A100 CSRB2P80A300	30 100 300
	100	CSRB2P100A30 CSRB2P100A100 CSRB2P100A300	30 100 300
	  Four Pole	10	CSRB4P10A30 CSRB4P10A100 CSRB4P10A300
16		CSRB4P16A30 CSRB4P16A100 CSRB4P16A300	30 100 300
20		CSRB4P20A30 CSRB4P20A100 CSRB4P20A300	30 100 300
25		CSRB4P25A30 CSRB4P25A100 CSRB4P25A300	30 100 300
32		CSRB4P32A30 CSRB4P32A100 CSRB4P32A300	30 100 300
40		CSRB4P40A30 CSRB4P40A100 CSRB4P40A300	30 100 300
63		CSRB4P63A30 CSRB4P63A100 CSRB4P63A300	30 100 300
80		CSRB4P80A30 CSRB4P80A100 CSRB4P80A300	30 100 300
100		CSRB4P100A30 CSRB4P100A100 CSRB4P100A300	30 100 300

## Double Pole

CSRB2P10A30      CSRB2P40A30  
 CSRB2P10A100      CSRB2P40A100  
 CSRB2P10A300      CSRB2P40A300

CSRB2P16A30      CSRB2P63A30  
 CSRB2P16A100      CSRB2P63A100  
 CSRB2P16A300      CSRB2P63A300

CSRB2P20A30      CSRB2P80A30  
 CSRB2P20A100      CSRB2P80A100  
 CSRB2P20A300      CSRB2P80A300

CSRB2P25A30      CSRB2P100A30  
 CSRB2P25A100      CSRB2P100A100  
 CSRB2P25A300      CSRB2P100A300

CSRB2P32A30  
 CSRB2P32A100  
 CSRB2P32A300

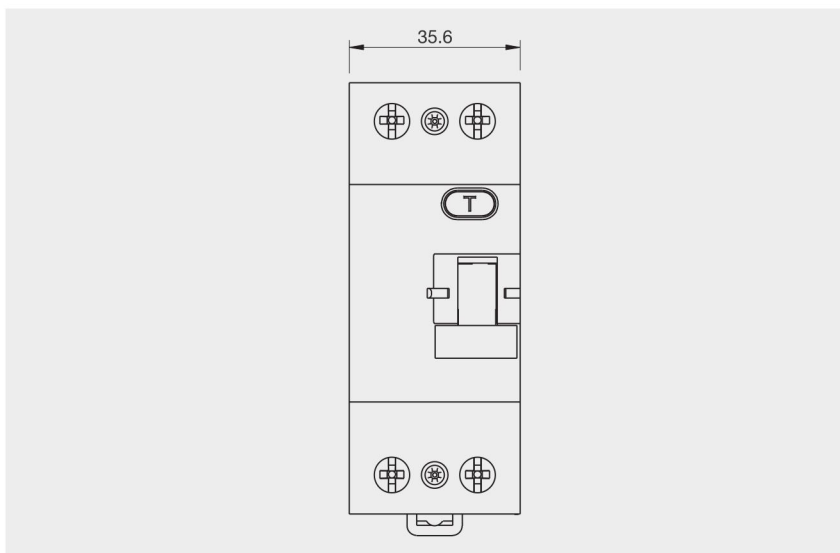

## Four Pole

CSRB4P10A30      CSRB4P40A30  
 CSRB4P10A100      CSRB4P40A100  
 CSRB4P10A300      CSRB4P40A300

CSRB4P16A30      CSRB4P63A30  
 CSRB4P16A100      CSRB4P63A100  
 CSRB4P16A300      CSRB4P63A300

CSRB4P20A30      CSRB4P80A30  
 CSRB4P20A100      CSRB4P80A100  
 CSRB4P20A300      CSRB4P80A300

CSRB4P25A30      CSRB4P100A30  
 CSRB4P25A100      CSRB4P100A100  
 CSRB4P25A300      CSRB4P100A300

CSRB4P32A30  
 CSRB4P32A100  
 CSRB4P32A300

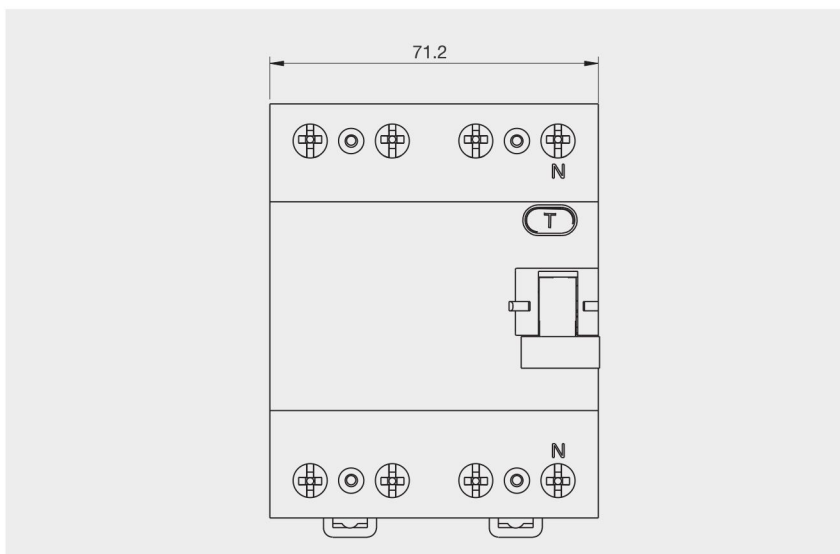

## Side view - Double & Four Pole

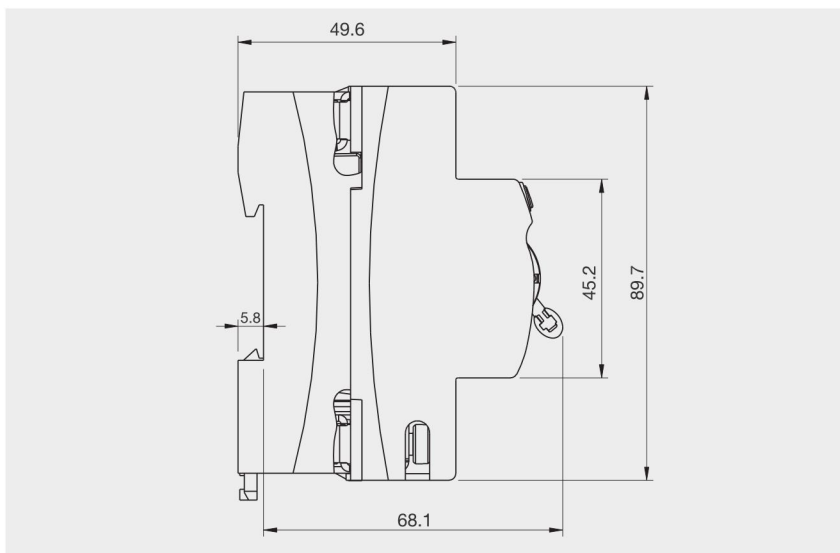

All dimensions are in mm

## Residual Current Circuit Breaker

**RCCB**  
Protects from  
SHOCK



**MCB**  
Protects from  
SHORT CIRCUIT  
AND OVERLOAD